

Herkules

TECHNIK  FÜR MENSCHEN

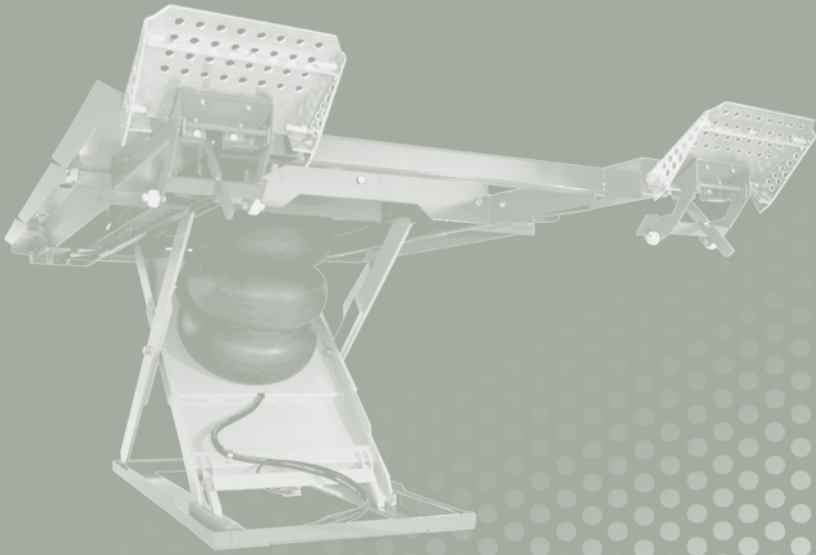

TECHNIQUE FOR PEOPLE



Herkules has designed and manufactured "technique for people" since 1974. In close co-operation with users "on site", we create workshop equipment which is economically smart with and through its ergonomics.

Superior technique setting standards: Lifts for paint- and bodyshops, automatic spray gun cleaners, dust extraction units. These are all examples for products which have become state of art for modern, future-orientated workshops.

The Herkules concept "technique for people" has been successfully incorporated. The products are worldwide highly acknowledged and distributed.



A selection of people and brands relying on us:

Akzo Coatings · Audi · BMW
Deutsche Bahn AG · Ford · Glasurit
Nexa Autocolor · Lufthansa
Volkswagen · Opel · Daimler AG
DuPont · Axalta · Porsche · Standox
Spies Hecker



By means of the newest tools and machines, Herkules produces and manufactures high quality paint- and bodyshop products at our headquarters in Kassel. Thanks to numerous user experiences, innovative technology and well-planned concepts, Herkules is able to make the products suit the high demands on the market.

The quality of our products - expressed through a 3 year guarantee on all lifts - is ensured during the entire production in Kassel. The lifts and the dust extractions are all 100 % made in Germany.

We would like to invite you to our exhibition and training centre in Kassel, where you can see and test all of our products.

Welcome!



Herkules is delighted to present some new products to you in this catalogue. They are all of the finest Herkules-quality, and loyal to our concept "technique for people" - this is not only our corporate philosophy, but also a promise to our customers.

Products:

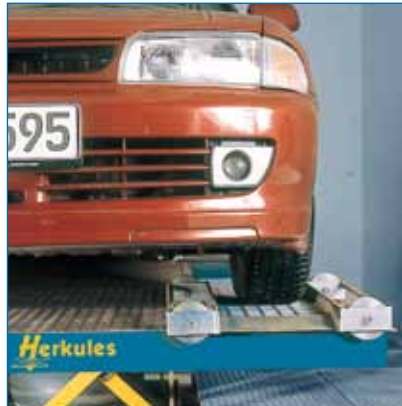

Lifts I Paint- and Bodyshop

Lifts HLS	6
Lift HLS-1200 For paint- and bodyshops	7
Lift HLS-1600 The professional lift with a working height of 1600 mm	8
HLS-3200 The lift with 3.2 to loading capacity	9
Lifts HLS-Duo	10
Lift HLS-1200 Duo Two Lift systems perfect combined	11
HLS-3200 Duo The double system lifting platform with increased lifting power	12
Cross beam For the free-lift of large vehicles	13
Lift HLS-1600 U Comfortable work on the top of the car	14
Lift HLQ For spraybooths with sideways transportation on roller trolley	15
Transmobil The workshop transportation system	16
Painter-Lift The working lift for the painter	18

Lifts II Workshop and Tyre service

Herkules-lift mobil The lift for the bodyshop	20
Herkules-lift RS Tyre service lift	22
Herkules-lift RS 3 to Tyre service lift	23
Lift K 700 Maintenance lift for the workshop	24
JACK 3 to The mobile jack for the flexible stroke of the soil	26
Lifts - a comparison (Overview)	27

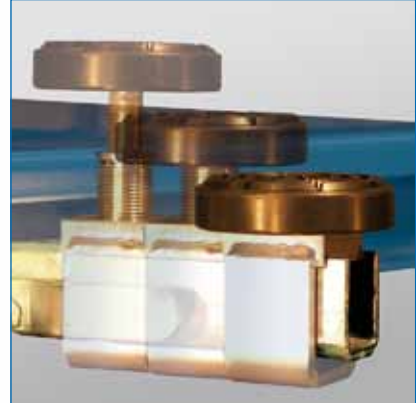

Cleanpoint The spray gun cleaning system

28

Herkules Aqua-Rinse Spray gun cleaner

31

Lucky table

32

Paint stand

32

Drain station

33

Cleaning

Hexadust Central dust extraction system

34

Hexacomb Turbo (Wall mounted solution)

NEW!

36

Hexacomb Turbo (Cabinet model)

NEW!

37

Hexacomb Turbo Dust extraction for self-installation

38

T-2 mobile

39

Hoses

40

Dust Extraction

Lucky Tender

41

Lucky Bumper

NEW!

41

Paper baler

42

Step-bench

42

Workshop

Herkules - your contact

43

Lifts HLS

The perfect lift for preparation and finish



The approved lifts HLS are available in three types for different demands.

All of them have:

- Stepless lifting heights
- Due to low construction height easy to drive on
- Simple access to interim drive over ramps and deviate loading ramps
- ATEX option with pneumatic lifting technology
- 3 years lift warranty



The easy installation facilitates an individual planning of body shops by using the existing space optimally.



Flush mounted with low pit depth.



Quality is increased by ergonomic work in an uncramped posture.



The lift HLS as in-ground installation in the spray booth.

HLS 1200

The perfect lift for paint and body-shops

Nearly 85 % of all car damages require the worker to work in a stooped position.

This causes fatigue and can also lead to long-term health problems. With the special paint-lift, the work can be done in an ergonomically correct upright position.

The work efficiency is increased and the quality is improved by better visual control opportunities.



on-ground

Simply fix with screws and dowels, and the lift is ready for immediate use.
Item No.: HLS1200-11

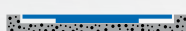

flush mounted

Flush mounted to concrete or grids.
Item No.: HLS1200-14



rail transport

Lift for rail transport
Item No.: HLS1200-13



Technical data:

Loading capacity	2.5 to	HLS 1200-14	
Weight	700 kg	Working height	~ 1000 mm
Air supply	8 bar	Pit depth	115 mm
		Lifting height	930 mm
HLS 1200-11		HLS 1200-13	
Working height	~ 1100 mm	Working height	~ 1100 mm
Object height only	110 mm	Object height only	135 mm
Lifting height	930 mm	Lifting height	930 mm

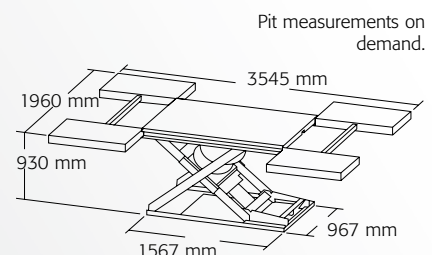

HLS 1600

The paint- and bodyshop lift with increased lifting height



Advantage of the lifts: The ergonomic work and the good visual control opportunities increase the efficiency and ensure the health of the employees.

The intelligent construction with the innovative extras and the extended lifting height makes the HLS-1600 the perfect professional lift for the future-oriented paintshops. Thanks to its compact construction, the lift is also suited for smaller workshops. Due to its fold down driving tracks and a drive-on ramp which is level with the rest of the lift, working with the HLS-1600 is easier than working with many other lift types.



on-ground

Ready for immediate use.
Easily accessible due to the ramps.

Item No.: HLS1600-11

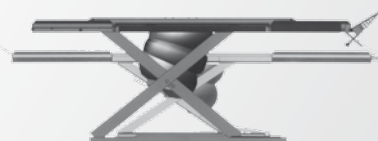

The new HLS-1600 has both: a new compact construction method and an extended lifting height which is superior to traditional lifts.



flush mounted

Flush mounted to concrete or grids.
Ideal for new installation sites.

Item No.: HLS1600-14

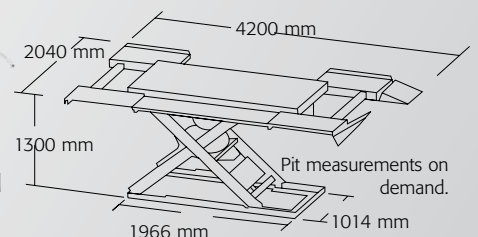

Technical data:

Loading capacity	3	to
Weight	800	kg
Air supply	8	bar

HLS 1600-11	
Working height	~1600 mm
Object height only	160 mm
Lifting height	1300 mm

HLS 1600-14	
Working height	~1400 mm
Pit depth	160 mm
Lifting height	1150 mm

HLS 3200

The lift with 3.2 to loading capacity



The HLS 3200 is with a loading capacity of 3.2 to constructed for heavy vehicles. This creates a safe work and provides the possibility also for SUVs and small vans.

The extended platform allows the lifting also for extended vehicles. The smooth lifting increase the access to damaged areas and the ergonomic work process.



on-ground
Ready to use immediately.
With ramps easily accessible.

Item No.: HLS 3200-11



flush mounted
Optimal flush mounted installation.
It is particularly advantageous for new buildings.
Item No.: HLS 3200-14



Technical data:

Loading capacity 3.2 to
Weight 750 kg
Air supply 8 bar

HLS 3200-11
Working height ~ 1050 mm
Object height only 122 mm
Lifting height variable to strain

HLS 3200-14
Working height ~ 950 mm
Pit depth 130 mm
Lifting height variable to strain

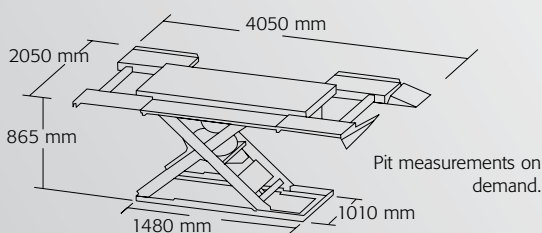

Lifts HLS Duo

Two lift systems perfect combined

One lift - two possibilities:

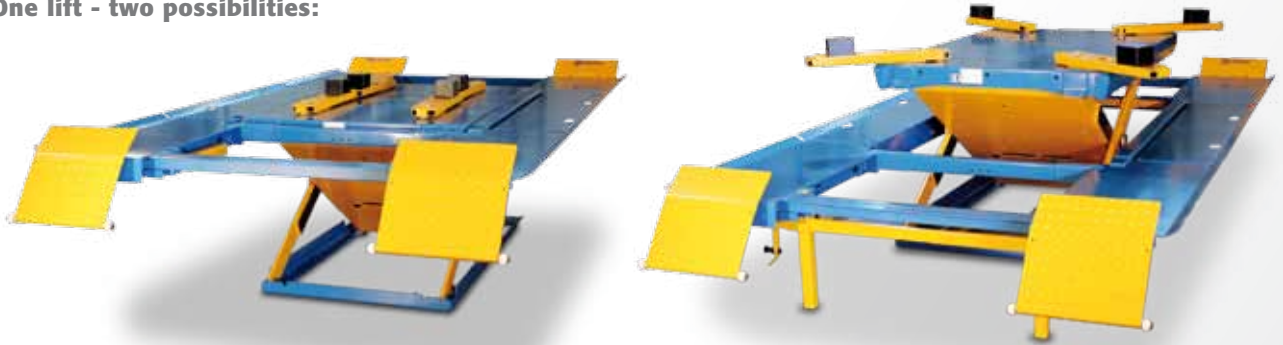

*The shown fold down supports are only for the on-ground version.

The approved HLS lifts are available in three types for different demands.

All of them have:

- Stepless lifting heights
- With ramps easily to drive-on
- Simple access to interim drive over ramp and deviate loading ramps
- ATEX option with pneumatic lifting technology
- 3 years lift warranty

Lifted on the wheels



The deviate loading ramps make the access to the panel so easy.

Wheel free lift



The stepless lifting height secures the ergonomic work process in the upper position.



Easy positioning of the lifting points also of extremely flat vehicles.



Loading ramps secure against fall down.

HLS 1200 Duo

The lift system with double operation

The workshop lifts for almost all standards. The lifting of the car could be either on wheels or for wheel free work.

Uncramped posture and better visibility improve quality thanks to different working heights that can be changed smoothly.

Due to its fold down driving tracks and ramps which is level with the rest of the lift, working is easier.



Alternatively 

on-ground

Item No.: HLS1200-Duo-11



flush mounted

Optimal flush mounted installation. It is particularly advantageous for new buildings.

Item No.: HLS1200-DUO-14



Technical data:

Loading capacity	2.5	to
Weight	850	kg
Air supply	8	bar

HLS 1200-DUO-11		
Working height	~ 1100	mm
Object height only	110	mm
Construction height with arms	155	mm
Lifting height	max. 930	mm

HLS 1200-DUO-14		
Working height	~ 1000	mm
Pit depth	115	mm
Lifting height	max. 825	mm

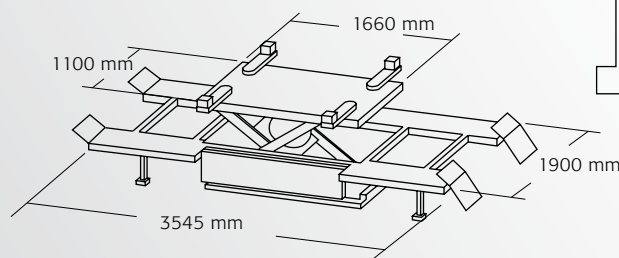

Supported area of the swivel arms in mm

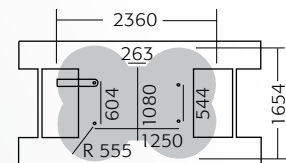

HLS 3200 Duo

TECHNIK



The double system lifting platform with increased lifting power

With 3.2 t loading capacity and the extended platform size the HLS 3200 is also made for heavy vehicles and small vans. Thanks to the extractable ramps (only on-ground version) a safe lifting from small to large vehicles is always attainable.

With the double functionality as standard lift as well as wheel free lift a multifunction workplace is realized.

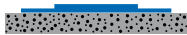

on-ground

Item No.: HLS3200-Duo-11



flush mounted

Item No.: HLS3200-DUO-14



Supported area of the swivel arms in mm

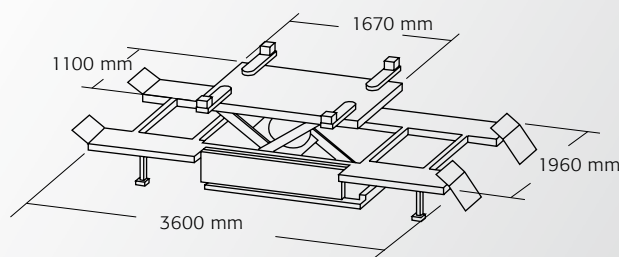
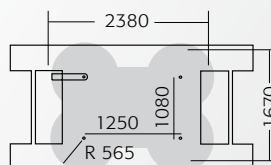

Technical data:

Loading capacity	3.2	to
Weight	850	kg
Air supply	8	bar

HLS 3200-DUO-11	
Working height	~ 1050 mm
Object height only	120 mm
Construction height with arms	170 mm
Lifting height variable to strain	

HLS 3200-DUO-14	
Working height	~ 950 mm
Pit depth	130 mm
Lifting height variable to strain	

Cross beam

The safe free-lift for large vehicles

For the wheel free-lift of large vehicles the cross beam is the applied solution, where the lifting points of the swivel arms are exceeded.

The cross beam will be placed on top of the swivel arms and is an option for the HLS 3200 DUO and and the RS 3 to.



Item No.: 300-375



A single worker can place the cross beam on top of the swivel arms.

The extractable ramps of the HLS 3200 Duo for the lifting of 4 wheels



The drive on ramps are adjustable in four catches. For this reason the lift can be adapted to the required wheel base.



Also the stopper ramps are adjustable in four catches. With extracted ramps the base is 3450 mm long.



The safe working level is ensured with maximum extraction.

HLS 1600-U

The immersible lift for a comfortable work on the top of the car

The HLS 1600-U allows the lowering of the car in the booth ground for easy work in the roof area.

This increases the productivity and the safety of the lift.

- Regular lifting for an ergonomic work at the vehicle
- Comfortable work on the top of the vehicle thanks to the immersion of the lift into the gratings of the booth or into the body shop without ladders or other insecure tools
- Smooth lifting and lowering to desired working height
- Perfect for SUVs (sport utility vehicle) and Vans

Item No.: HLS1600-15



Optimal approach to the vehicle and to the top of the vehicle.

Technical data:

Loading capacity	3.0	to
Length of the platform	4030	mm
Width of the platform	1985	mm
Depth of the pit	475	mm
Weight	920	kg
Air supply	8	bar

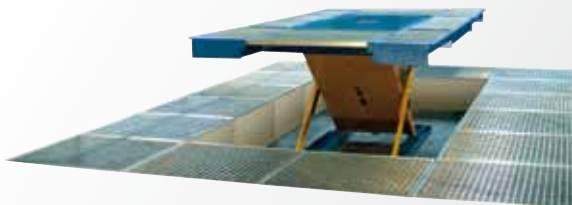

The HLS1600-U lifted for the work on the lower part of the vehicle.

Working height ~ 850 mm

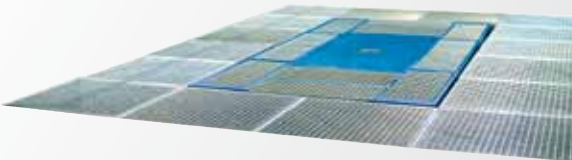

The HLS1600-U on the bottom for an easy access.

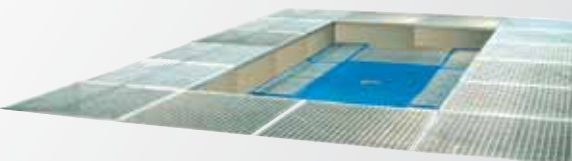

The HLS1600-U immersed for the work on the upper parts of the vehicle.

Recessed depth up to 300 mm



Herkules HLQ

Drive-over lift with trolleys for side transportation

For spraybooths equipped with trolleys for side transportation. Safe vehicle lifting on its wheels.

Work under better visual conditions without fatigue. While lifted, even the lower parts of the car can be reached comfortably with the spray gun. This increases the work efficiency and improves the quality.



Item No.: HLQ-01

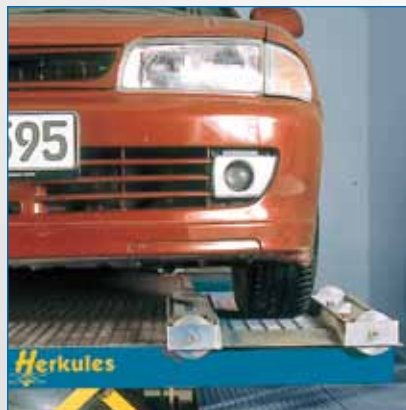

While on the trolley, the vehicle is lifted on its wheels. When the lift is lowered, the trolleys are guided into the rails.



The vehicle can easily be pushed sideways into the drying chamber. The lift can be used for the next vehicle.



Optimal use of existing space by sideways transportation in the body shop.

Technical data:

Loading capacity 2.5 to
 Weight 500 kg
 Air supply 8 bar
 Working height ~ 800 mm
 The flush-mounted lift is prepared for the installation into grids with adjustment to the existing rails.

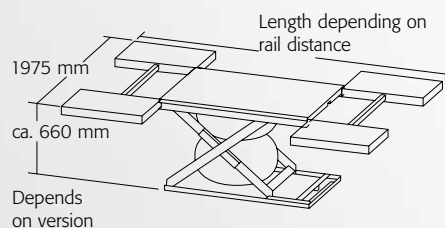

Transmobile

Rail-free handling and transportation system



- Reduces vehicle transportation times
- Can easily and safely be operated by only one person
- Makes the most of your space thanks to its tight entry angle
- Powerful self-drive with no harmful exhaust gases
- Covered vehicle surfaces remain undamaged
- Final cleaning of vehicle interior is no longer necessary
- Our product makes your work easier and increases the work quality

The revolutionary system for modern paintshops. Thanks to a quicker and safer work routine, the Transmobile creates new capacity.

The Transmobile drastically reduces the work involved in vehicle transportation around the shop. Your benefit is an even better used time for new jobs.

The transportation system consists of the remote controlled automotive transmobile, and the lift HLS and HLS Duo.

Can be used in any shop with a level surface - even in the spraybooth with grid floor.

The use of the Transmobile pays off: better workshop utilisation, lower wage costs and a great amount of time saved.

Transmobile

2.5 to Version
3.2 to Version

Item No.: HLT-03
Item No.: HLT-04

Technical data:

Loading capacity	2.5/3.2	to
Weight	560/600	kg
Drive	24	V



Transmobile: The film
Take a look at our website. Quick and easy!
www.herkules.de





The cars are on lifts from the moment the work is started right through to the final inspections. It can safely and quickly be moved to subsequent workstations.



Can be used in any shop with a level floor - even in the spraybooth with grid floor.



The lifts for Transmobile are made for use with moving transport – easy to use.



Moving the vehicles through tight spaces is easy and safe.



The remote control is easy to use.

Painter

The working lift for the painter

The new development for the state-of-the-art paint shop.

Safe lifting for all works around the car.

- Smooth lifting and lowering
- For prep area and spray booth
- Easy to move
- Low space requirements
- More safety for your employees



Painter 01

Working height up to 3.25 m
Platform dimensions 2000 x 700 mm
Loading capacity 150 kg
Item No.: Painter-01



Painter 02

Working height up to 4 m
Platform dimensions 3500 x 700 mm
Loading capacity 150 kg
Item No.: Painter-02

Painter 04

Working height up to 4 m
Platform dimensions 2000 x 700 mm
Loading capacity 150 kg
Item No.: Painter-04



Painter 05

Working height up to 4 m
Platform dimensions 3500 x 700 mm
Loading capacity 250 kg
Item No.: Painter-05

Air supply 8 bar



Painter 01



Painter secures safe standing and ergonomic working position for painter when working at higher vehicles.



The painter is easily moveable with the wheels. Both at prep work and spray booths – excellent for small spaces.

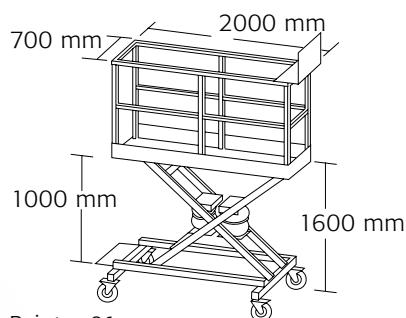

Painter 01



On the platform are several air supplies as well as storage space for the tools. Therefore they are always within reach.

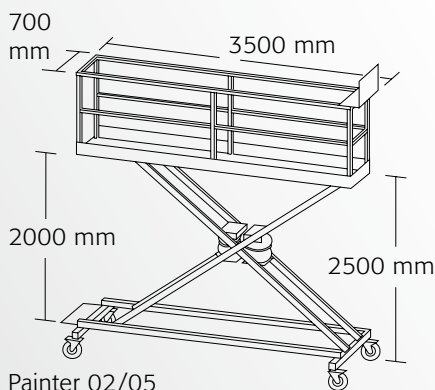

Painter 02/05

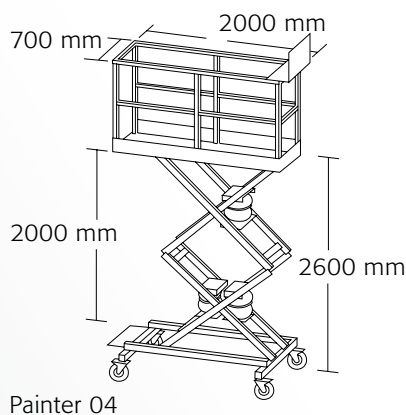

Painter 04



Herkules-lift mobile

The new lift for bodyshops

A fast mobile lift for service jobs with interchangeable lifting devices.



Herkules-lift mobile

The lift is ready for immediate use - no installation necessary! With an additional set of wheels it is mobile in the shop.

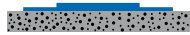

on-ground

Ready for immediate use.
Item No.: HM1100-01



- Fast lifting
- Ergonomic lifting height
- Various possibilities of use
- Small space requirements
- No installation required
- Operated solely by air pressure



flush mounted

Optimal in-ground installation.
Item No.: HM1100-04



With wheels and pole handle (optional) it can be moved around at any time.

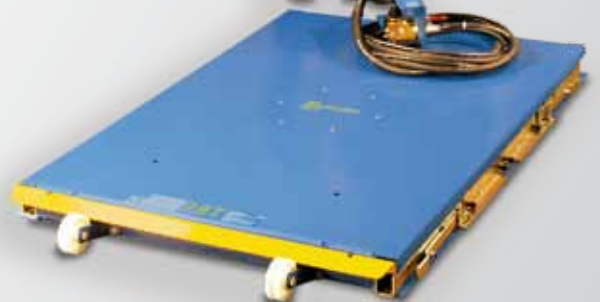

Herkules-lift mobile



Lifts II

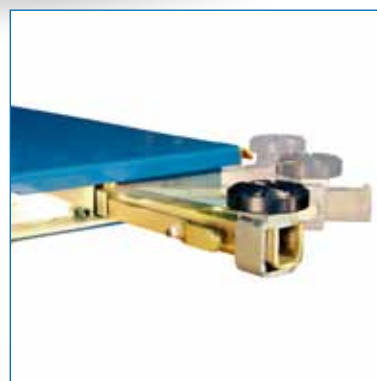
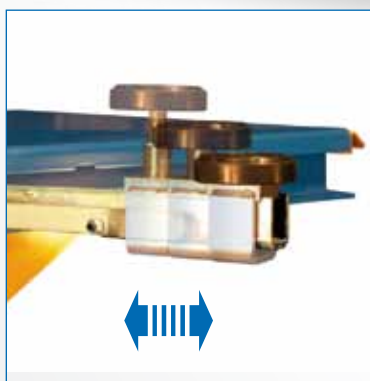

The swivel arms easily reach the vehicles' original lifting points. All swivel arms are moveable horizontally at the lift.

The lifting dishes negotiate a distance of 140 mm height and they are moveable at the swivel arm.

The radius of the swivel arms allows also the safe fixing of wide vehicles.

Technical data:

Loading capacity	2.8	to
Weight	510	kg
Air supply	8	bar
Item No.: HM 1100-01		
Working height	~ 1100	mm
Object height	115	mm
Lifting height	930	mm
Item No.: HM 1100-04		
Working height	~ 1000	mm
Pit depth	115	mm
Lifting height	825	mm

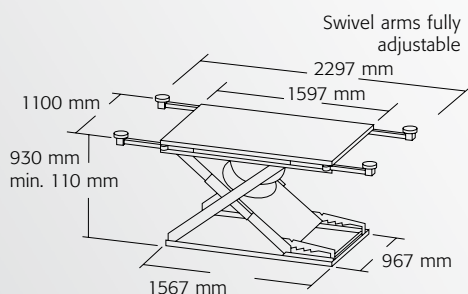

Supported area of the swivel arms in mm
HM 1100-01

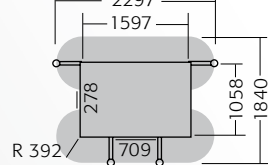

Supported area of the swivel arms in mm
HM 1100-04

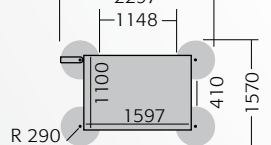

Herkules-lift RS

Fast tyre- and brake-service

TECHNIK  FÜR MENSCHEN



Tyre service lift Herkules-lift RS

Due to the low construction height, the easy positioning of the blocks through outside markings and the high lifting speed, the lift enables you to service more vehicles in a short time. This increases the productivity of your shop, especially in the high seasons.

- 2.5 t lifting capacity
- No installation required
- Ready for immediate use
- Operated solely by air pressure
- Mobile with handle and wheels (optional)

Item No.: RS570-01



Safe lifting every time thanks to the easy fixing of original lifting points. If ramps are removed, short wheel based cars can also be serviced.

The lift is equipped with telescoping arms, and therefore it is also suitable for small vans and cars with long wheel distance.

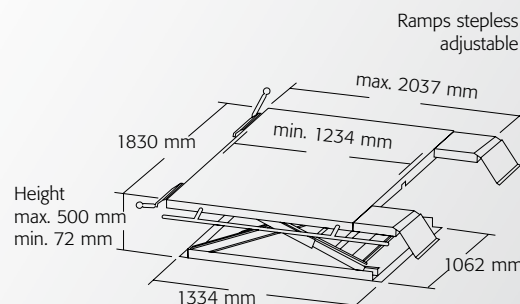

Technical data:

Loading capacity	2.5	to
Weight	520	kg
Air supply	8	bar
Working height	~500	mm
Object height only	72	mm
Lifting height	428	mm

Herkules-lift RS 3 to



Tyre service lift Herkules-lift RS 3 to

Due to the increased lifting capacity and the big lift plate, fast tyre fitting is not a problem even for large vehicles. Due to the low construction height and the fast lifting speed, the Herkules-lift RS 3 enables you to service more vehicles in a short time. This increases the productivity of your shop especially in peak seasons.

The lift is ready for immediate use - compressed air supply and a level floor is all you require.

- Loading capacity 3 to
- Non-damaging access due to a low drive-over height
- Swivel arms easily reach the vehicles' original lifting points
- Smooth pneumatic lifting up to 500 mm
- No damage to vehicle wheels due to rounded-off angles of the swivel arms
- Side foot protection plates guard the operator
- No installation required
Immediate use without installation



With the cross beam (page 13) the lifting points of large vehicles are ensured.

Item No.: RS-3T-01



Technical data:

Loading capacity	3	to
Weight	550	kg
Air supply	8	bar
Working height	~500	mm
Object height only	77	mm
Lifting height	423	mm

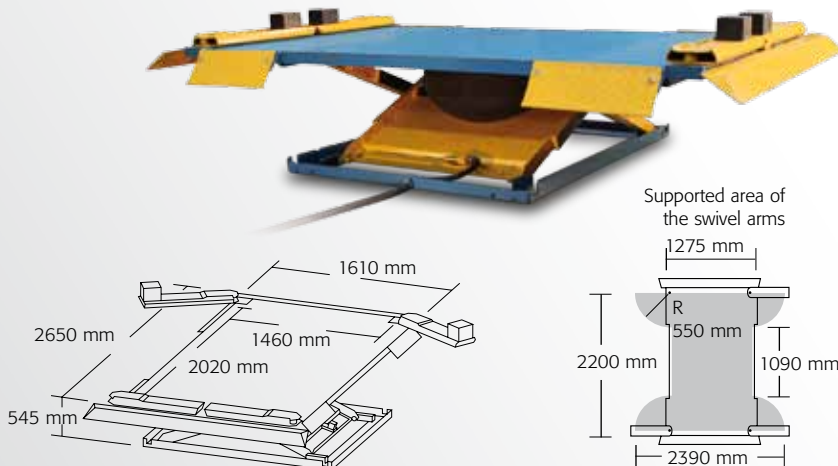

Herkules-lift K 700

Increased lifting height - more possibilities

TECHNIK  FÜR MENSCHEN



Tyre Service Lift K700



Item No.: K700-45

- Loading capacity 2.8 to
- Non-damaging access due to a low drive-over height
- Swivel arms easily reach the vehicles' original lifting points
- Smooth pneumatic lifting up to 930 mm
- Ergonomic work in upright position
- No damage to vehicle wheels due to rounded-off angles of the swivel arms
- No installation required
Immediate use without installation

The K700 is an universally applicable lift for tyre service workshops.

The lifting height of 930 mm allows an ergonomic work at a height of approx. 1100 mm for all work to be accomplished at the tyre service, brake-service or tuning operations.

With a loading capacity of 2.8 to the K700 is also suitable for work on heavy Limousines and SUV's.

Technical data:

Loading capacity	2.8	to
Weight	720	kg
Air supply	8	bar
Working height	~ 1100	mm
Object height only	110	mm
Lifting height	930	mm

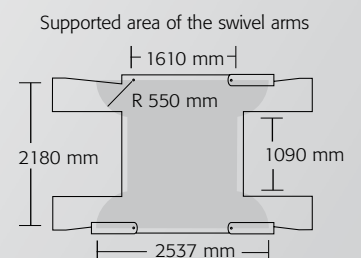
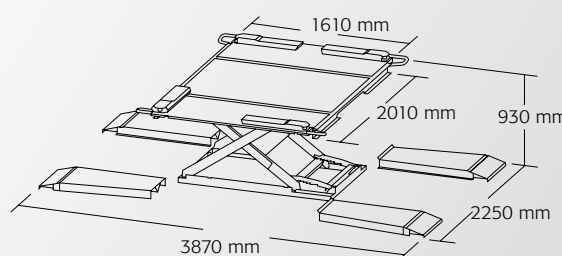

Herkules-lift K 700



The double-wedge ramp allows an easy and non-damaging access even with lowered vehicles.



Thanks to the radius, the swivel arms reach easily the vehicle's original lifting points.

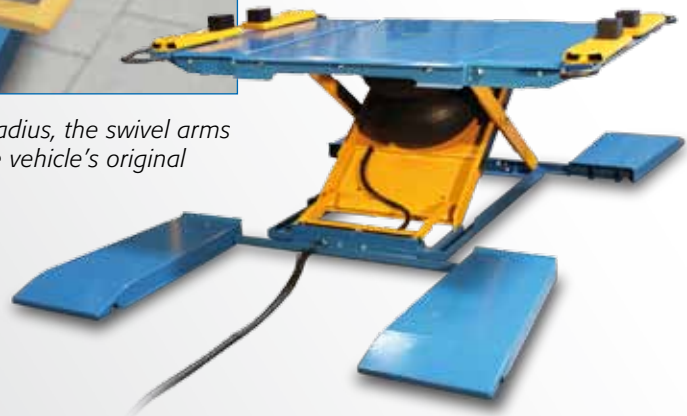

Herkules-lift JACK 3 to

The mobile workshop jack.
Can easily and securely be used on
the workshop floor.

- **Really flat**
just 120 mm
- **Super lifting height**
410 mm
- **Really light**
just 8 kg
- **Really strong**
3.0 to loading capacity



Item No.: 300-246

Technical data:

Loading capacity	3	to
Height max.	410	mm
Height min.	120	mm
Weight	8	kg
Air supply	8	bar



	HLS 1200-11	HLS 1200-14	HLS 1600-11	HLS 1600-14	HLS 3200-11	HLS 3200-14	HLS 1200-Duo-11	HLS 1200-Duo-14	HLS 3200-Duo-11	HLS 3200-Duo-14	HLS 1600-15	HLQ-01	HM 1100-01	HM 1100-04	RS 570-01	RS 3t-01	K 700-45
Scope of duties																	
Paint- and body work	●	●	●	●	●	●	●	●	●	●	●	●	●	●			
Tyework							●	●	●	●			●	●	●	●	●
Driving specifications																	
Over ramps 4 pieces		●		●		●		●		●	●						
Over ramps 2 pieces	●		●		●		●		●								
Drive through possibility	(●)	●	(●)	●	(●)	●	(●)	●	(●)	●	●	●	●	●	●	●	●
Lifting specifications																	
Chassis supported							●	●	●	●			●	●	●	●	(●)
Wheel supported	●	●	●	●	●	●	●	●	●	●	●	●					
Technical specifications																	
Lifting Capacity in to	2.5	2.5	3	3	3.2	3.2	2.5	2.5	3.2	3.2	3	2.5	2.8	2.8	2.8	3	2.8
Object height in cm	11	11	15	11	12	12	11	11	12	12	16	10	11	11	7	8	11
Working height in cm	110	100	160	145	max. 105	max. 95	110	100	max. 105	max. 95	115	80	110	110	70	70	110
Net lifting height in cm	82	82	115	115	max. 77	max. 77	82	82	max. 77	max. 77	115	64	82	82	50	50	82
Air supply	max. 8 bar																
Installation specifications																	
Flush Mounted		●		●		●		●		●	●	●		●			
On Ground	●		●		●		●		●				●		●	●	●
Mobile													(●)				
Rail												●					

Standard ● optional (●)



Awarded and recommended by
the market leader of spray guns



Spray gun
cleaning machines
at the highest
level:

Cleanpoint

The innovation.

The patented magnetic gun holder
fixates a spray gun in a position where
the gun's air channels are protected.
The air channel is free connected to
the solvent entering, so there is no
longer the risk of solvent entering the
air channels.

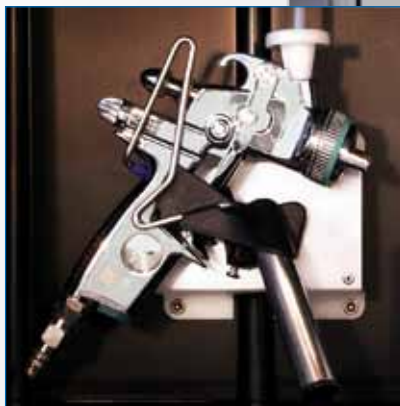

The superior cleaning system for the painter



- **Fully automatic gun cleaning** inside and outside.
- Improved cleaning performance and **more features**.
- **Magnetic gun holder** fixates the gun in an optimal washing position.
- **Simultaneous** manual and automatic cleaning of up to 4 guns.
- Convenient handling due to **ergonomic design**.
- Persuasive design in **quality stainless steel**.
- For **solvents** as well as **water**.



The innovative washing room for the automatic wash process: The Auto-Box. The powerful wash pumps and the high efficiency of the nozzles make the washing result more efficient consuming less solvent.

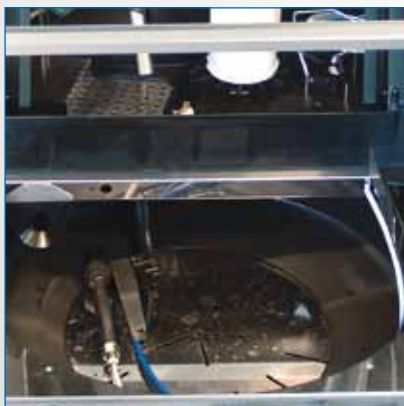

The workstation is equipped with a manual brush for recirculation solvent and with a spray gun with clean solvent.



Attractive design and impressive functionality. The magnetic holder for the spray gun can be individually placed - whether inside or outside of the unit.



Another major innovation is the magnetic gun holder. The new magnetic gun holder pulls the trigger to open the paint channel and fixates a gun in seconds, in one simple step. It fixates the gun in a position where the gun's air channels are protected, facing downwards, so there is no risk of solvent entering the air channels. Through clever design, there is no longer any need for separate extension tubes, trigger clips, air purge lines etc.

Easy control by foot pedals. The powerful components of the simultaneous cleaning are guaranteed up to four spray guns at the same time.



All commercial containers (60 liters) can be easily ranked in the trolley. Each trolley is designed with a tray as overflow protection.



CP-Quattro

A complete solution for solvent based paints. Two automatic washing chambers and two basins for manual cleaning in one machine.

For solvents Item No.: CP-QUATTRO



CP-Duo

All components for automatic and manual cleaning in one device.

For solvents Item No.: CP-DUO



CP-Uno

Compact station for manual cleaning with a brush and a spray nozzle.

For solvents Item No.: CP-UNO



CP-Duo-Aqua

All components for automatic and manual cleaning in one machine. For water or water-based solvent (e.g. Aquasolve)

Item No.: CP-DUO-AQUA

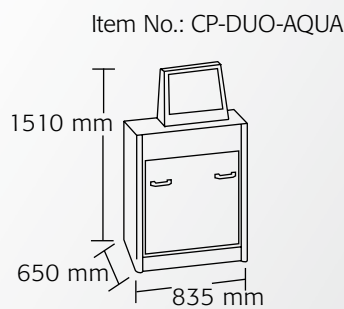
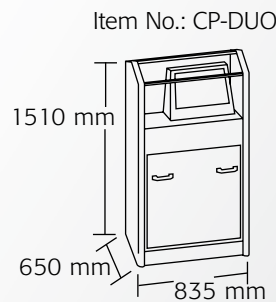
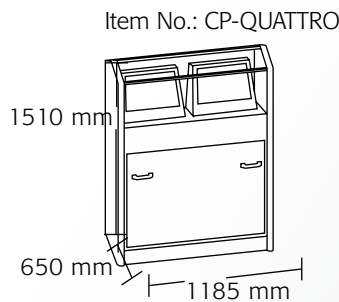

Technical data:

Weight CP Quattro	95	kg
Weight CP Duo	75	kg
Weight CP Uno	70	kg
Weight CP Duo Aqua	65	kg
Compressed air supply	7-12	bar
Solvent pressure	2	bar
Capacity pump	10l/min.	

Subject to technical changes.
Extraction solutions are available (optional)



AquaSolve

The new concentrate for the water-based gun cleaning.

- Makes cleaning quick and easy
- For the automatic cleaning
- Anti-corrosion additives and cleaners to protect the spray gun

- Long-lasting cleaning action
- Disposal by coagulation remains
- Applicable for all color brands

Item No.: DH-230120

Herkules Aqua-Rinse

TECHNIK



The clean station for the quick colour change of water borne paint

The clean station is special designed for the disposable cup systems. The proper cleaning for spray guns is the result of spray out, rinsing and drying. All functions are integrated in one compact solution.

Leaving the spray booth to clean the spray gun is time consuming and inconvenient. Proper cleaning means better quality after each paint change.



Spray out the remaining paint



Rinse the paint channel



Wipe the air cap



Dry the gun

Equipment features:

- Paint spray out funnel
- Paint channel rinse nozzle activates pump when pressed
- Air cap brush
- Air gun for drying the spray gun
- Diaphragm pump
- Clean water container

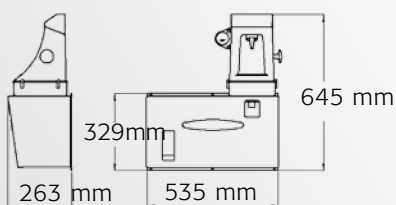

Item No.: DH-QR-10

Lucky Table

The preparation table for the paintshop

Herkules Lucky table

This table is made of **stainless steel** and has a lot of storage space for painting materials and tools. Everything is at your hand, saving both time and effort.

The **lowered working surface** prevents solvent overflow. It has also got an **outflow tunnel** for pouring into a collecting tank. A **paper roll holder** is available as an accessory.

Optimum solvent extraction:

Thanks to the defined extraction at the bottom of the working surface, reliable extraction is possible. The solvent particles concentrated at the bottom are optimally drawn off through strong suction.

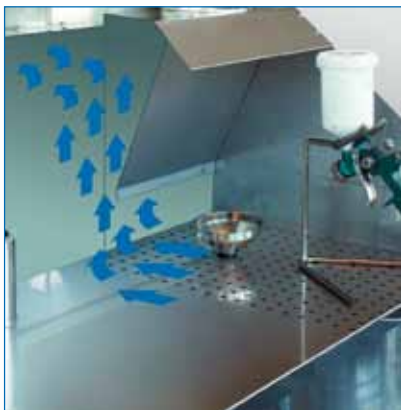

The extraction system can be connected to an already existing system. Herkules has a pneumatic extraction system available as an accessory.

Technical data:

Item No.:	LT-05
Width	1200 mm
Item No.:	LT-06
Width	1800 mm
Overall height	1395 mm
Depth	650 mm
Paper roll holder and extraction system available as accessories.	



Paint stand



Herkules paint stand

The quick and safe painting and assembly stand for paint- and bodyshops.

- Has a wide range of adjustments
- Robust but easy to handle
- Extendable

Item No.: BL-01

Drain station

To collect residue of lacquers

The Herkules **drain station** is the cost-saving add-on unit for automatic spray gun cleaning systems. Drained guns and cups go easy on the cleaning agent in the system. The increased service life saves a lot of resources.

- Thanks to the increased service life it saves solvents
- With blow-out channel for cleaning the gun interior
- Suitable for conventional and waterbased materials
- Clean workstation
- Optional extraction system is available as an accessory

Item No.: CP-TG01



The residues of lacquers are collected in a canister. An optional exhaust avoids odour and healthrisks.



The residues of lacquers are collected in a canister. An optional exhaust avoids odour and healthrisks.



Spray guns and paint cups are simply placed in the drip openings.

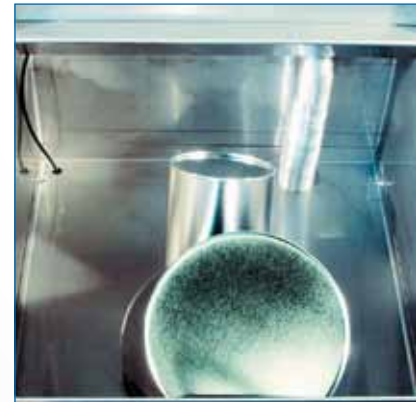

Spray cups will just be placed above the drain opening.

Technical data:

Height	1020 mm
Width	400 mm
Depth	500 mm



The **drain station** is the ideal add-on unit for all automatic spray gun cleaning systems. It drastically increases the service life of cleaning agents in the systems.

The modular designed dust extraction system

Herkules Hexadust dust extraction system

Vacuum dust extraction solutions for workshops of any size. An individual analysis of your workshop setting will let us configure the ideal set up for your shop.

The Hexagon energy head or alternatively the multifunctional terminal will provide work places with vacuum power, air pressure and electricity. The standard automatic start and stop enables healthy working, a clean workshop and energy savings.



T 2 - Turbo
Up to 2 sanders at the same time.

Item No.: E1W



T 2 - Turbo
Up to 2 sanders at the same time.

Item No.: E1S



T 4 - Turbo
Up to 4 sanders at the same time.

Item No.: E1C



T 6 - Turbo
Up to 8 sanders at the same time.

Item No.: E3K



The Hexadust dust extraction provides all working places in the workshop. The Hexagon energy head is compatible with all sanding tools.

Single- or multiple user system?

We've got them both and would be happy to consult you about your choice.

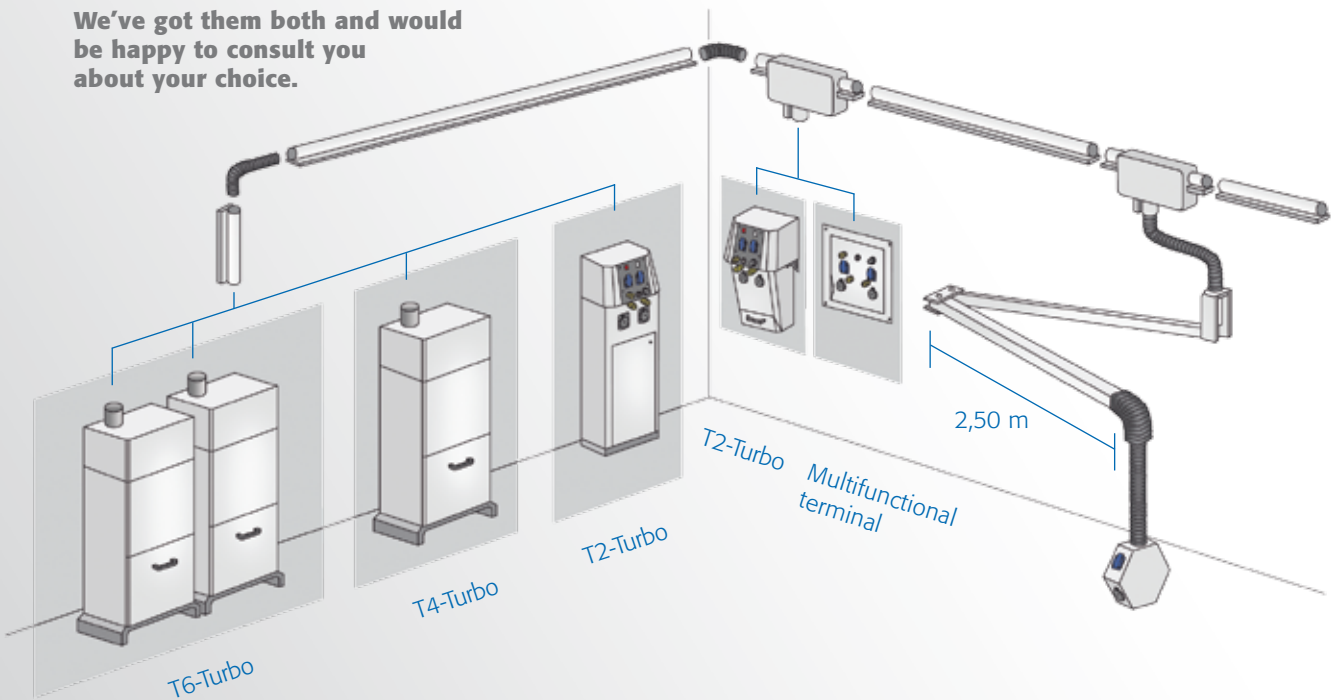

Automatic system start for both air and electrical tools as well as an automatic pneumatic filter cleaning are standard equipment.

With Hexadust dust extraction systems you have the choice between Hexagons with ceiling or wall assembly as well as swivel arm with a length of 5 m. The connection is a result of a pipe system.



Hexacomb Turbo

A vacuum system for multiple users

The authentic multiple user system for the paint shop.
A new efficiency standard for vacuum systems that are designed for self-installation.



NEW!



Wall mounted solution

- Turbine unit 1.3 kW / 230 V
- Swivel arm 5 m
- Hexagon energy head
- Holder for hoses and tools

Item No.: HEXA-COMB-T2W



Hexacomb Turbo



With the swivel arm you reach several working places in the preparation area.

NEW!



Including cabinet and accessories.

The cabinet model Hexacomb Turbo can also be embedded into a wall.

Cabinet model

- Turbine unit 1.3 kW / 230 V
- Swivel arm 5 m
- Hexagon energy head
- Holder for hoses and tools

Item No.: HEXA-COMB-T2S

NEW!

The new Hexacomb combines recent product design, high efficiency and an user-friendly handling.

- Gallant design
- Adjustable compressed air connection
- Particularly silent
- Easy and safe removal of the dust bags

- ✓ Filling level indication through LED-signal
- ✓ Adjustable air pressure with manometer
- ✓ Real multiple user system: double connection for power supply, compressed air and extraction
- ✓ Powerful turbine
- ✓ Silent turbine due to optimized insulation
- ✓ Ergonomic and dust-reduced dust disposal through a sliding plate and dust bag holders

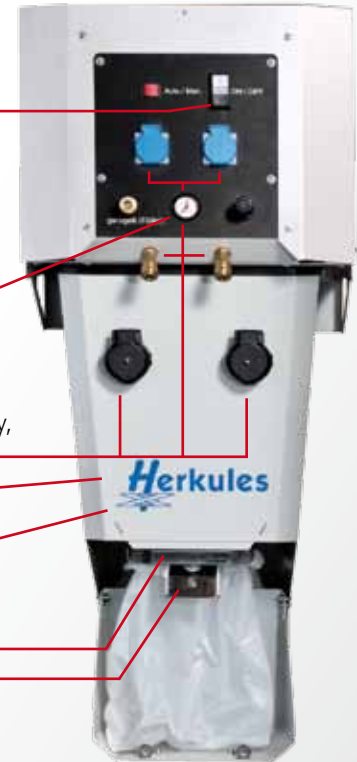

Safety guidance of the swivel arms through a smooth-running gear ring connection.



Ergonomic and dust-reduced dust disposal through a sliding plate and dust bag holders.



Dust-reduced disposal by opening the sliding plate. The dust goes into the dust bag.

Very silent:

With a maximum of 64 dB more silent than a modern vacuum cleaner.

Technical data:

Motor power	1300	W
Circulatory	220	m ³ /h
Depression	220	mbar
Filter area	10470	cm ²
Noise level	max. 64	dB
Electric tension	230	V
	50-60	Hz

Jet fighter with a distance of 30 m	140
Pain threshold	130
Threshold of illness	120
Chain saw with a distance of 1 m	110
Disco with a distance of 1 m to the speakers	100
Diesel engine with a distance of 10 m	90
Border of a public highway 5 m	80
Vacuum cleaner with a distance of 1 m	70
Herkules Hexacomb Turbo	64
Normal speech with a distance of 1 m	60
Dishwasher	50
Quiet conversation	40
Hum of refrigerator	30
Rest noises in a television studio	20
Rustling of leaves in the distance	10

New filter cleaning:

Filling level indication of the filter area through LED-signal. By opening the sliding piston the filters are cleaned automatically and the dust bag can be changed in a dust reduced way.

T-2 Mobile

The mobile working place
in the prep area

All the necessary tools and
materials you need at your hand.

Herkules T-2 Mobile

- Lockable tool case
- Rubber layered working and storage shelf

Integrated strong vacuum turbine

- Strong vacuum power 1.1 kW / 230 V
- Long life time (25.000 hours of operation)
- Automatic on/off for electronic and air-operated machines
- Automatic filter cleaning
- Silent turbine due to optimized insulation
- Dust-reduced disposal
- Compatible for all traditional sanding tools like Rupes, Hutchins, Festo SIA etc.

Item No.: T2M



- Standard:
- Back for accessories and sanding materials
 - Hose holder



no swivel-joint

360° swivel-joint



Available hoses

Vacuum hose

F1A 5 m
F1B 7 m
F1C 9 m

Vacuum and compressed air

F1D 5 m
F1E 7 m
F1F 9 m

F3D 5 m
F3E 7 m
F3F 9 m

Vacuum with compressed air and grounding

F1D-E 5 m
F1E-E 7 m
F1F-E 9 m

Vacuum and electricity

F2D 5 m
F2E 7 m
F2F 9 m

Adaptor

For Festool IAS 2 machines

Item No.: 340-007

For Festool IAS 3 machines

Item No.: 300-404

between turbine and hose
 or between hose and Hexagon

Lucky Tender

The carrying- and storage-system for the paint preparation and final assembly

With the „Lucky Tender“ long ways to the storage are history.

Two stabilized basements in the lower area, a flexible grating ground and at any place with two small parts mountable box provides organization and clear view.

Prepared parts like doors, spoiler and wings can be stored in a safe way. The „Lucky Tender“ increases your productivity considerable.

- Cushioned rack for bulks
- Safety fixation with tension belt
- Continuous extractable bearings
- Box, grating rack and grab handle can be individually positioned
- Clearly grid boxes and racks
- Easy shunting

Item No.: 300-297

The Tender provides beside the gratings and racks for bulks additionally capacity for working tools and consumables.



Technical data:

Length 900 mm Width 680 mm
 Height 2020 mm Weight 45 kg

Subject to technical changes.



Safety shunting in the body shop.

Lucky Bumper

The storage and transport rack for large parts

For safe storage and easy transportation of bulky vehicle parts.

- Adjustable in many ways
- Padded shelves
- Easy to rank

Art.Nr. 300-399

NEW!

Technical data:

Length 1200 mm Width 800 mm
 Height 2000 mm Weight 28 kg



Paper baler

Provides space and reduces waste disposal charges

Paper baler

Up to 5 to pressing capacity reduces volume drastically. Whether packing or masking - paper from the paintshop - the big front flap swallows it all!
Tied up easily in pressed state.

Achieves a 20 times more effective use of waste containers, and drastically reduces the waste disposal charges.

Thanks to the set of wheels with lockable casters a relocation is possible at any time.



Item No.: PAP-01

Technical data:

Capacity	5.0	to
Weight	250	kg
Air supply	8	bar
Flap opening:	415 x 680	mm
Bundle weight:	25 - 50	kg

1645 mm
Height with wheels
1670 mm

850 mm 885 mm



Aluminium step-bench

For painting large vehicles

An essential "helping hand" when painting the roofs of larger vehicles such as vans and small trucks. When it is not in use it can easily be put away - it does not require a lot of space.

Item No.: 300-257

Technical data:

Loading capacity	120	kg
Weight	5.0 / 6.5	kg
Dimensions	1000 x 330 x 325	mm
	1190 x 330 x 600	mm



Your contact at Herkules:



Karsten Grötecke
Export Manager
Phone +49 5 61/5 89 07 68
Mobile +49 1 72/5 74 48 57
groetecke@herkules.de



Dr. Peter Löprick
Managing Director
Phone +49 5 61/5 89 07 29
loeprick@herkules.de



Kirsten Clemen
Customer Service
Phone +49 5 61/5 89 07 26
clemen@herkules.de



Andrea Kuntke
Executive Assistant
Phone +49 5 61/5 89 07 29
kuntke@herkules.de



Jörg Andres
Customer Service
Phone +49 5 61/5 89 07 33
andres@herkules.de

V 14

Subject to technical changes.



Headquarters & Production :
Herkules Hebetchnik GmbH
Falderbaumstr. 34
D-34123 Kassel
Founded: 1974

Member of the Hedson Group



Phone: +49 561 / 5 89 07-0 · Fax: +49 561 / 5 89 07-45 · e-mail: info@herkules.de · Internet: www.herkules.de